

# HAL4803 Low Noise, Linear Hall Effect Sensor ICs with Analog Output

## FEATURES AND BENEFITS

- GaAs + Si Hybrid Programmable Linear Hall-Effect IC
- Range of non-destructive supply voltage: VDD 4V ~ 25V
- Quick response for magnetic field with wide bandwidth
- Customer programmable, high resolution offset and sensitivity trim
- High sensitivity Hall element for maximum accuracy
- Extremely low noise and high resolution achieved via proprietary Hall element and low noise amplifier circuits

## DESCRIPTION

The HAL4803 programmable linear Hall-effect current sensor IC has been designed to achieve high accuracy and resolution without compromising bandwidth. This ratiometric Hall-effect sensor IC provides a voltage output that is proportional to the applied magnetic field. The customer can configure the sensitivity through programming on the VCC and output pins, to optimize performance in the end application. The quiescent voltage output is user-adjustable around 50% of the supply voltage, VCC, and the output sensitivity is adjustable within the range of 1.5 to 10 mV/G. The sensor IC incorporates a highly sensitive Hall element with a BiCMOS interface integrated circuit that employs a low noise small-signal high-gain amplifier, a clamped low-impedance

### Absolute Maximum Ratings

Table 1.HAL4803 Absolute Maximum Ratings

Characteristic	Symbol	Notes	Rating	Unit
Forward Supply Voltage	V <sub>CC</sub>		6	V
Reverse Supply Voltage	V <sub>RCC</sub>		-0.1	V
Forward Output Voltage	V <sub>OUT</sub>		25	V
Reverse Output Voltage	V <sub>ROUT</sub>		-0.1	V
Output Source Current	I <sub>OUT(source)</sub>	V <sub>OUT</sub> to GND	10	mA
Output Sink Current	I <sub>OUT(sink)</sub>	V <sub>CC</sub> to V <sub>OUT</sub>	10	mA
Operating Ambient Temperature	T <sub>A</sub>		-40 to 150	°C
Storage Temperature	T <sub>stg</sub>		-40 to 150	°C
Maximum Junction Temperature	T <sub>J(max)</sub>		150	°C

### Typical Application Drawing

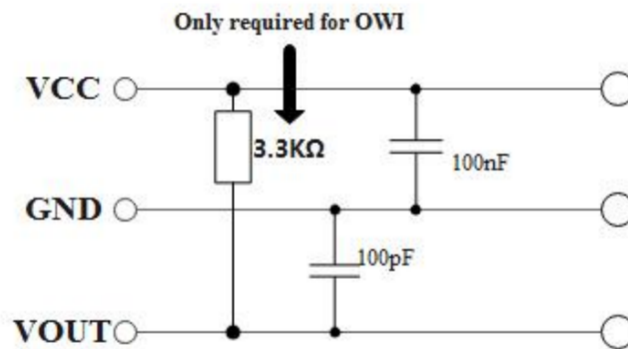

**OPERATING CHARACTERISTICS: valid through the full operating temperature range, TA, CBYPASS = 0.1  $\mu$ F, VCC = 5 V; unless otherwise specified**

Table 2. HAL4803 OPERATING CHARACTERISTICS

Characteristics	Symbol	Test Conditions	Min.	Typ.	Max.	Unit <sup>1</sup>
<b>Electrical Characteristics</b>						
Supply Voltage	VCC		4.5	5.0	5.5	V
Supply Current	ICC	No load on VOUT	–	6.5	10	mA
Power-On Time <sup>2</sup>	tPO	TA = 25°C	–	–	1	ms
Undervoltage Lockout(UVLO) Threshold <sup>2</sup>	VUVLOH	TA = 25°C	–	3.3	3.8	V
	VUVLOL	TA = 25°C	–	3	–	V
Power-On Reset Release Time <sup>2</sup>	tPORR	TA = 25°C, VCC rising	–	60	–	$\mu$ s
Supply Zener Clamp Voltage	Vz	TA = 25°C, ICC = 30 mA	5.6	6	–	V
Internal Bandwidth	BWi	TA = 25°C	100	–	–	kHz
<b>Output Characteristics</b>						
Propagation Delay Time <sup>2</sup>	tPD	TA = 25°C	–	1.5	–	$\mu$ s
Rise Time <sup>2</sup>	tR	TA = 25°C	–	2.5	–	$\mu$ s
Response Time <sup>2</sup>	tRESPONSE	TA = 25°C	–	1.5	–	$\mu$ s
Output Saturation Voltage <sup>2</sup>	VSAT(HIGH)	TA = 25°C	4.65	–	–	V
	VSAT(LOW)	TA = 25°C	–	–	0.2	V
Broken Wire Voltage <sup>2</sup>	VBRK(HIGH)	TA = 25°C	–	VCC	–	V
	VBRK(LOW)	TA = 25°C,	–	100	–	mV
<b>Output Characteristics (continued)</b>						
Noise <sup>4</sup>	VN	TA = 25°C, CL = 1 nF, BW f = BWi	–	1.0	–	mGRMS/ $\sqrt{\text{Hz}}$
		TA = 25°C, CL = 1 nF, BW f = BWi	–	3.0	–	mVp-p
		TA = 25°C, CL = 1 nF, BW f = BWi	–	1.0	–	mVRMS
DC Output Resistance	ROUT		–	8	10	$\Omega$
Output Load Resistance	RL(PULL UP)	VOUT to VCC	3.3	–	–	k $\Omega$
	RL(PULL DOWN)	VOUT to GND	3.3	–	–	k $\Omega$
Output Load Capacitance <sup>5</sup>	CL	VOUT to GND	–	100	–	pF
Output Slew Rate <sup>6</sup>	SR	Sens = 2.5mV/G, CL = 1 nF	–	250	–	V/ms
<b>Quiescent Voltage Output (VOUT(Q))<sup>2</sup></b>						
Initial Unprogrammed Quiescent Voltage Output <sup>2,7</sup>	VOUT(Q)init	TA = 25°C	2.40	2.50	2.60	V
Quiescent Voltage Output Programming Range <sup>2,3,8</sup>	VOUT(Q)PR	TA = 25°C	2.49	–	2.51	V
<b>Sensitivity (Sens)<sup>2</sup></b>						
Initial Unprogrammed Sensitivity <sup>7</sup>	Sensinit	TA = 25°C	0.5	–	1.5	mV/G
Sensitivity Programming Range <sup>3,8</sup>	SensPR	TA = 25°C	1.5	–	10	mV/G

<b>Factory Programmed Sensitivity Temperature Coefficient</b>						
Sensitivity Drift Through Temperature Range <sup>2,8</sup>	$\Delta$ SensTC	TA = 25°C to 150°C	-2.0	-	2.0	%
		TA = -40°C to 25°C	-2.5	-	2.5	%
Sensitivity Temperature Coefficient	TCSens	Programmed at TA = 25°C, calculated relative to Sens at 150°C	-	0.016	-	%/°C
Average Sensitivity Temperature Compensation Step Size	StepSENSTC		-	< 0.1	-	%
<b>Factory Programmed Quiescent Voltage Output Temperature Coefficient</b>						
Quiescent Voltage Output Drift Through Temperature Range <sup>2,8</sup>	$\Delta$ VOUT(Q)TC	TA = 25°C to 150°C, Proportional to sensitivity	-10	-	10	G <sup>9</sup>
		TA = -40°C to 25°C, Proportional to sensitivity	-12.5	-	12.5	
Average Quiescent Voltage Output Temperature Compensation Step Size	StepQVOTC		-	0.6	-	mV
<b>Error Components</b>						
Linearity Sensitivity Error <sup>2,10</sup>	LinERR		-0.5	< ±0.2	0.5	%
Symmetry Sensitivity Error <sup>2</sup>	SymERR		-1	< ±0.5	1	%
Ratiometry Quiescent Voltage Output Error <sup>2,11</sup>	RatERRVOUT(Q)	Through supply voltage range (relative to VCC = 5 V), TA = 25°C	-0.75	0	0.75	%
Ratiometry Sensitivity Error <sup>2,11</sup>	RatERRSens	Through supply voltage range (relative to VCC = 5 V), TA = 25°C	-0.75	< ±0.25	0.75	%
Ratiometry Clamp Error <sup>2,12</sup>	RatERRCLP	Through supply voltage range (relative to VCC = 5 V), TA = 25°C	-	< ±1.0	-	%

<sup>1</sup> 1 G (gauss) = 0.1 mT (millitesla).

<sup>2</sup> See Characteristic Definitions section.

<sup>3</sup> Sens and VOUT(Q) scale with VCC due to ratiometry.

<sup>4</sup> Noise, measured in mVPP and in mVRMS, is dependent on the sensitivity of the device.

<sup>5</sup> Output stability is maintained for capacitive loads as large as 100nF.

<sup>6</sup> High-to-low transition of output voltage is a function of external load components and device sensitivity.

<sup>7</sup> Raw device characteristic values before any programming.

<sup>8</sup> Exceeding the specified ranges will cause sensitivity and Quiescent Voltage Output drift through the temperature range to deteriorate beyond the specified values.

<sup>9</sup> G = mV/(mV/G).

<sup>10</sup> Linearity applies to output voltage ranges of ±2 V from the quiescent output for bidirectional devices.

<sup>11</sup> Percent change from actual value at VCC = 5 V, for a given temperature, through the supply voltage operating range.

<sup>12</sup> Percent change from actual value at VCC = 5 V, TA = 25°C, through the supply voltage operating range.

## CHARACTERISTIC PERFORMANCE DATA

### Response Time ( $t_{RESPONSE}$ )

Sensitivity = 10 mV/G,  $C_{BYPASS}=0.1 \mu\text{F}$ ,  $C_L=100 \text{ pF}$

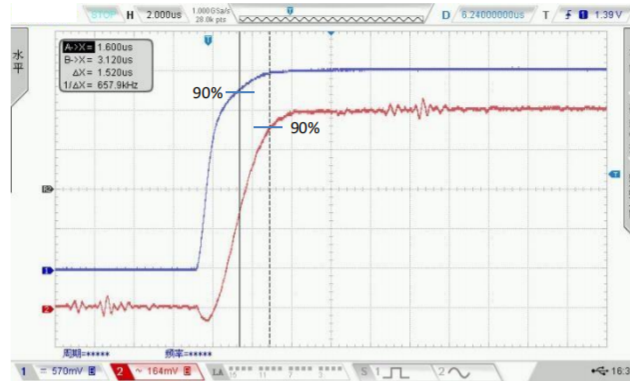

### Propagation Delay ( $t_{PD}$ )

Sensitivity = 10 mV/G,  $C_{BYPASS}=0.1 \mu\text{F}$ ,  $C_L=100 \text{ pF}$



### Rise Time ( $t_R$ )

Sensitivity = 10 mV/G,  $C_{BYPASS}=0.1 \mu\text{F}$ ,  $C_L=100 \text{ pF}$

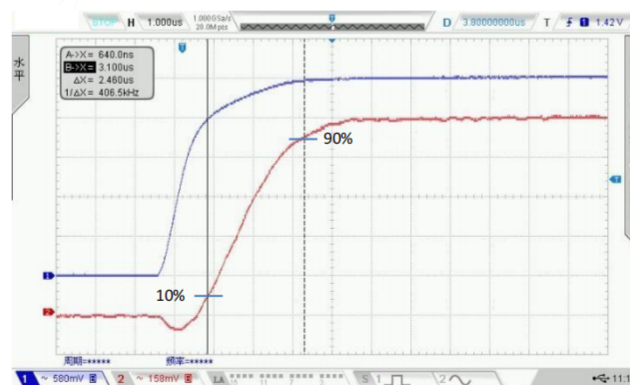

## CHARACTERISTIC DEFINITIONS

### Power-On Time ( $t_{PO}$ )

When the supply is ramped to its operating voltage, the device requires a finite time to power its internal components before responding to an input magnetic field. Power-On Time,  $t_{PO}$ , is defined as: the time it takes for the output voltage to settle within  $\pm 10\%$  of its steady state value under an applied magnetic field, after the power supply has reached its minimum specified operating voltage,  $V_{CC(min)}$ , as shown in Figure 1.

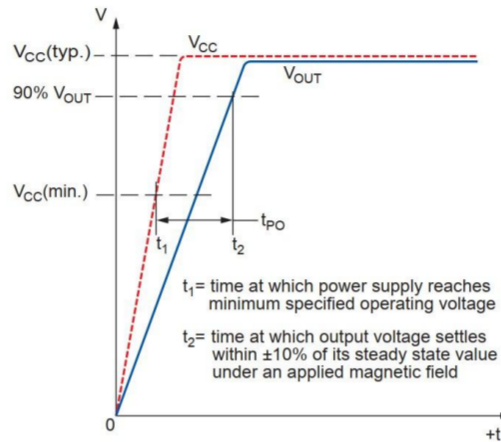

Figure 1. Power-on Time Definition

### Temperature Compensation Power-On Time ( $t_{TC}$ )

After Power-On Time,  $t_{PO}$ , elapses  $t_{TC}$  is also required before a valid temperature compensated output.

### Propagation Delay ( $t_{PD}$ )

The time interval between a) when the applied magnetic field reaches 20% of its final value, and b) when the output reaches 20% of its final value (see Figure 2).

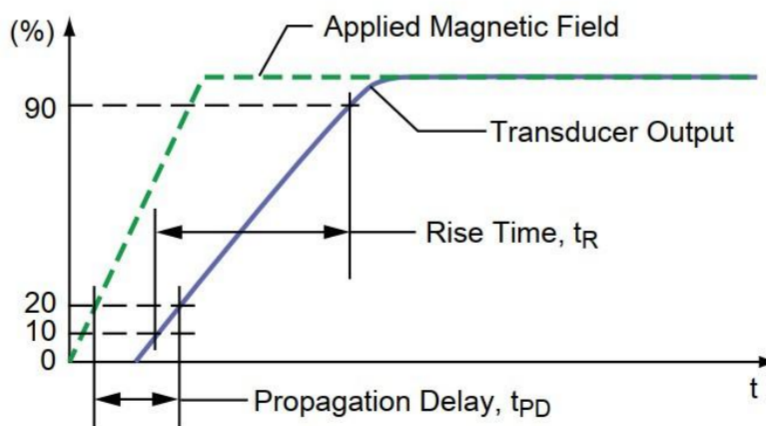

Figure 2: Propagation Delay and Rise Time Definitions

### Rise Time ( $t_R$ )

The time interval between a) when the sensor IC reaches 10% of its final value, and b) when it reaches

90% of its final value (see Figure 2). Both  $t_r$  and  $t_{RESPONSE}$  are detrimentally affected by eddy current losses observed in the conductive IC ground plane.

**Response Time ( $t_{RESPONSE}$ )**

The time interval between a) when the applied magnetic field reaches 90% of its final value, and b) when the sensor reaches 90% of its output corresponding to the applied magnetic field (see Figure 3).

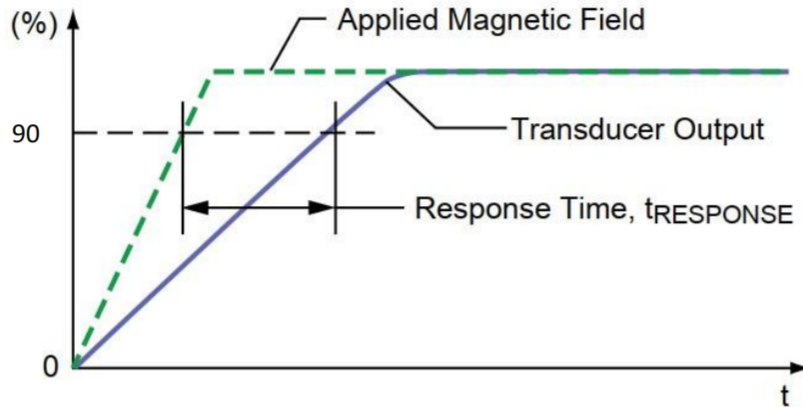

Figure 3: Response Time Definition

**Quiescent Voltage Output ( $V_{OUT(Q)}$ )**

In the quiescent state (no significant magnetic field:  $B = 0$  G), the output,  $V_{OUT(Q)}$ , has a constant ratio to the supply voltage,  $V_{CC}$ , throughout the entire operating ranges of  $V_{CC}$  and ambient temperature,  $T_A$ .

**Initial Unprogrammed Quiescent Voltage Output ( $V_{OUT(Q)init}$ )**

Before any programming, the Quiescent Voltage Output,  $V_{OUT(Q)}$ , has a nominal value of  $V_{CC} / 2$ , as shown in Figure 5.

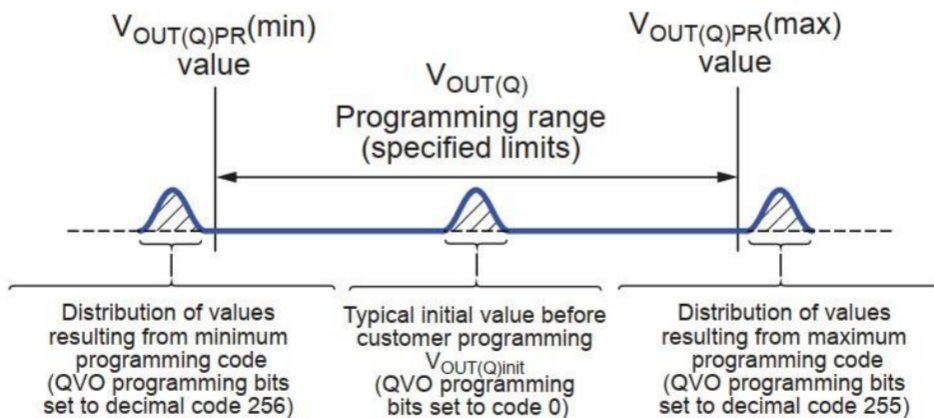

Figure 4: Quiescent Voltage Output Range Definition

**Quiescent Voltage Output Drift Through Temperature**

### Range ( $\Delta V_{OUT(Q)TC}$ )

Due to internal component tolerances and thermal considerations, the Quiescent Voltage Output,  $V_{OUT(Q)}$ , may drift from its nominal value through the operating ambient temperature,  $T_A$ . The Quiescent Voltage Output Drift Through Temperature Range,  $\Delta V_{OUT(Q)TC}$ , is defined as:

$$V_{OUT(Q)TC} = V_{OUT(Q)TA} - V_{OUT(Q)EXPECTED(TA)}, \quad (5)$$

$\Delta V_{OUT(Q)TC}$  should be calculated using the actual measured values of  $\Delta V_{OUT(Q)TA}$  and  $\Delta V_{OUT(Q)EXPECTED(TA)}$  rather than programming target values.

### Sensitivity (Sens)

The presence of a south polarity magnetic field, perpendicular to the branded surface of the package face, increases the output voltage from its quiescent value toward the supply voltage rail. The amount of the output voltage increase is proportional to the magnitude of the magnetic field applied. Conversely, the application of a north polarity field decreases the output voltage from its quiescent value. This proportionality is specified as the magnetic sensitivity, Sens (mv/G), of the device, and it is defined as:

$$\text{Sens} = \frac{V_{OUT(BPOS)} - V_{OUT(BNEG)}}{BPOS - BNEG}, \quad (6)$$

where BPOS and BNEG are two magnetic fields with opposite polarities.

### Initial Unprogrammed Sensitivity (Sensinit)

Before any programming, Sensitivity has a nominal value that depends on the SENS\_COARSE bits setting. Each HAL4803 variant has a different SENS\_COARSE setting.

### Sensitivity Programming Range (SensPR)

The magnetic sensitivity, Sens, can be programmed around its initial value within the sensitivity range limits: SensPR(min) and SensPR(max). Exceeding the specified Sensitivity Range will cause Sensitivity Drift Through Temperature Range  $\Delta \text{Sens}_{TC}$  to deteriorate beyond the specified values. Refer to the Quiescent Voltage Output Range section for a conceptual explanation of how value distributions and ranges are related.

### Average Fine Sensitivity Programming Step Size (StepSENS)

Refer to the Average Quiescent Voltage Output Programming Step Size section for a conceptual explanation.

### Sensitivity Programming Resolution (ErrPGSENS)

Refer to the Quiescent Voltage Output Programming Resolution section for a conceptual explanation.

### Sensitivity Temperature Coefficient (TCSENS)

Device sensitivity changes as temperature changes, with respect to its programmed sensitivity temperature coefficient, TCSENS. TCSENS is programmed at 150°C, and calculated relative to the nominal sensitivity programming temperature of 25°C. TCSENS (%/°C) is defined as:

$$TCSENS = \frac{Sens_{T2} - Sens_{T1}}{Sens_{T1}} * \frac{1}{T2 - T1} * 100\%, (7)$$

where T1 is the nominal Sens programming temperature of 25°C, and T2 is the TCSENS programming temperature of 150°C.

**Sensitivity Drift Through Temperature Range (ΔSensTC)**

Second order sensitivity temperature coefficient effects cause the magnetic sensitivity, Sens, to drift from its expected value over the operating ambient temperature range, TA. The Sensitivity Drift Through Temperature Range, ΔSensTC, is defined as:

$$\Delta Sens_{TC} = \frac{Sens_{TA} - Sens_{(25^{\circ}C)}}{Sens_{(25^{\circ}C)}} \times 100\%, (8)$$

**Linearity Sensitivity Error (LinERR)**

The HAL4803 is designed to provide a linear output in response to a ramping applied magnetic field. Consider two magnetic fields, B1 and B2. Ideally, the sensitivity of a device is the same for both fields, for a given supply voltage and temperature. Linearity error is present when there is a difference between the sensitivities measured at B1 and B2.

**Linearity Error**

Linearity error is defined as the ratio of the maximum perpendicular deviation (MFD) to the full scale (F.S.), where MFD is the maximum difference between the OUT voltage (Vout) and the approximate straight line calculated in the sensitivity definition. Definition formula is shown in below:

$$LinERR = 100\% * \frac{MFD}{F.S.} = 100\% * \frac{MFD}{V_H - V_L}, (9)$$

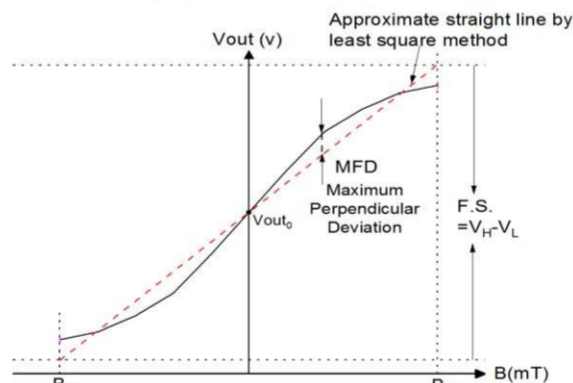

Figure 5: Output characteristics of HAL4803

**Symmetry Sensitivity Error (SymERR)**

The magnetic sensitivity of an HAL4803 device is constant for any two applied magnetic fields of equal magnitude and opposite polarities. Symmetry Error, SymERR (%), is measured and defined as:

$$SymERR = (1 - \frac{Sens_{BPOS}}{Sens_{BNEG}}) * 100\%, (10)$$

where SensBx is as defined in equation 12, and BPOSx and BNEGx are positive and negative magnetic

fields such that  $|BPOSx| = |BNEGx|$ .

#### **Ratiometry Error (RatERR)**

The HAL4803 device features ratiometric output. This means that the Quiescent Voltage Output,  $V_{OUT(Q)}$ , magnetic sensitivity, Sens, and Output Voltage Clamp,  $V_{CLP(HIGH)}$  and  $V_{CLP(LOW)}$ , are proportional to the Supply Voltage,  $V_{CC}$ . In other words, when the supply voltage increases or decreases by a certain percentage, each characteristic also increases or decreases by the same percentage. Error is the difference between the measured change in the supply voltage relative to 5 V, and the measured change in each characteristic. The ratiometric error in Quiescent Voltage Output,  $RatERRV_{OUT(Q)}$  (%), for a given supply voltage,  $V_{CC}$ , is defined as:

$$RatERRV_{OUT(Q)} = \left(1 - \frac{V_{OUT(Q)(V_{CC})} * \frac{5V}{V_{CC}}}{V_{OUT(Q)(5V)}}\right) * 100\% , (11)$$

The ratiometric error in magnetic sensitivity,  $RatERR_{Sens}$  (%), for a given Supply Voltage,  $V_{CC}$ , is defined as:

$$RatERR_{Sens} = \left(1 - \frac{Sens(V_{CC}) * \frac{5V}{V_{CC}}}{Sens(5V)}\right) * 100\% , (12)$$

#### **Power-On Reset Voltage (VPOR)**

On power-up, to initialize to a known state and avoid current spikes, the HAL4803 is held in Reset state. The Reset signal is disabled when  $V_{CC}$  reaches  $V_{UVLOH}$  and time  $t_{PORR}$  has elapsed, allowing output voltage to go from a high impedance state into normal operation. During power-down, the Reset signal is enabled when  $V_{CC}$  reaches  $V_{PORL}$ , causing output voltage to go into a high impedance state. (Note that detailed description of POR and UVLO operation can be found in the Functional Description section).

#### **Power-On Reset Release Time (tPORR)**

When  $V_{CC}$  rises to  $V_{PORH}$ , the Power-On Reset Counter starts. The HAL4803 output voltage will transition from a high impedance state to normal operation only when the Power-On Reset Counter has reached  $t_{PORR}$  and  $V_{CC}$  has exceeded  $V_{UVLOH}$ .

#### **Undervoltage Lockout Threshold (VUVLO)**

If  $V_{CC}$  drops below  $V_{UVLOL}$  output voltage will be locked to GND. If  $V_{CC}$  starts rising HAL4803 will come out of Lock state when  $V_{CC}$  reaches  $V_{UVLOH}$ .

#### **Output Saturation Voltage (VSAT)**

When output voltage clamps are disabled, output voltage can swing to a maximum of  $V_{SAT(HIGH)}$  and to a minimum of  $V_{SAT(LOW)}$ .

#### **Broken Wire Voltage (VBRK)**

If the GND pin is disconnected (broken wire event), output voltage will go to  $V_{BRK(HIGH)}$  (if a load resistor is connected to  $V_{CC}$ ) or to  $V_{BRK(LOW)}$  (if a load resistor is connected to GND).

### Detecting Broken Ground Wire

If the GND pin is disconnected, the VOUT pin will go to a high impedance state. Output voltage will go to  $V_{BRK(HIGH)}$  if a load resistor  $R_{L(PULLUP)}$  is connected to VCC or  $V_{BRK(LOW)}$  if a load resistor  $R_{L(PULLDWN)}$  is connected to GND. The device will not respond to any applied magnetic field. If the ground wire is reconnected, HAL4803 will resume normal operation.

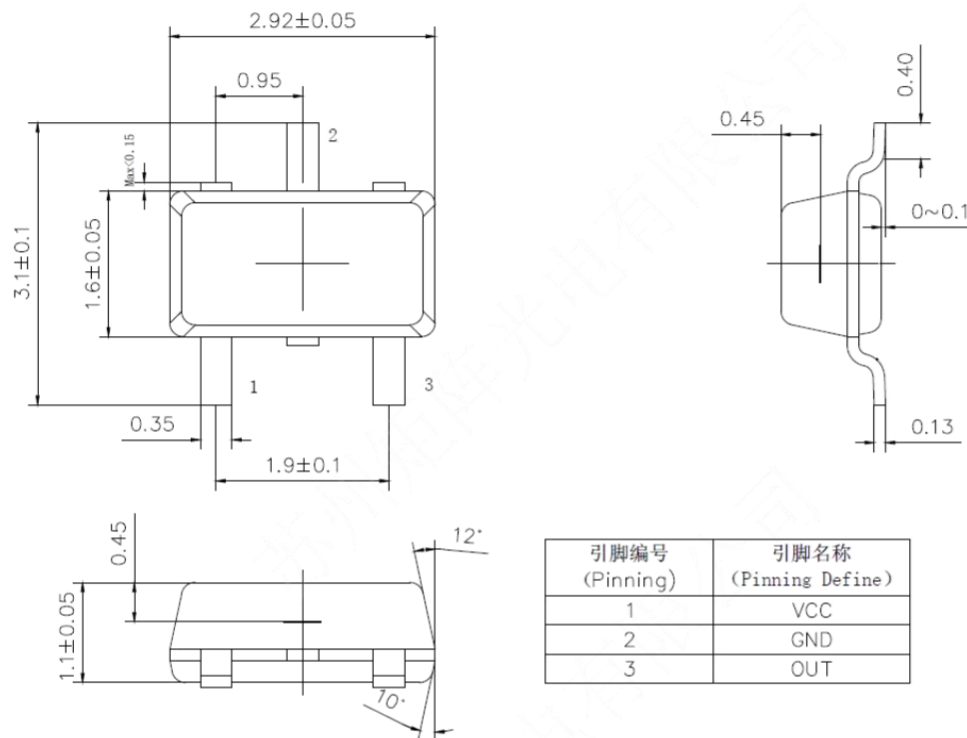

<sup>1</sup>Unmarked tolerances are controlled according to  $\pm 0.05$ mm while the angel tolerance is  $\pm 1^\circ$ .